



Lot Sizes, Fire Separation Distances, and Setback Requirements for Manufactured Home Parks

Minimum Lot Sizes

Paragraphs (A), (B), and (C) of O.A.C. 4781-12-08

- Park constructed or substantially altered on or between 12/17/1951 to 12/31/1960 and not substantially altered after 12/31/1960:
 - 1,250 square feet
- Park constructed or substantially altered on or between 1/1/1961 and 6/30/1971 and not substantially altered after 6/30/1971:
 - 1,800 square feet
- Park constructed or substantially altered on or after 7/1/1971:
 - 3,600 square feet

Minimum Fire Separation Distances

Paragraphs (E) and (G) of O.A.C. 4781-12-08

- Park constructed on or before 12/31/1960 and not substantially altered after 6/30/1971:
 - 10 feet between sides of manufactured homes
 - 8 feet between the end of any manufactured home and a side of any manufactured home
 - 5 feet between the ends of manufactured homes placed end to end
- Park constructed after 12/31/1960 or substantially altered after 6/30/1971:
 - Manufactured homes placed side to side or at an angle less than 90 degrees:
 - Average of 15 feet, with no distance less than 12 feet at any point
 - Manufactured homes placed side to end or at an angle equal to or greater than 90 degrees, but less than 135 degrees:
 - 10 feet
 - Manufactured homes placed end to end or at an angle equal to or greater than 135 degrees:
 - 5 feet

Minimum Setbacks

Paragraphs (F) and (H) of O.A.C. 4781-12-08

- Park constructed on or before and not substantially altered after 6/30/1971:
 - 10 feet between a manufactured home and any building, public roadway, street, alley, and any right-of-way designated by the Ohio Department of Transportation or local jurisdiction
 - 5 feet between a manufactured home and any park roadway, parkway, and the manufactured home park property line
- Park constructed or substantially altered after 6/30/1971:
 - 15 feet between a manufactured home and any building, public roadway, street, alley, and any right-of-way designated by the Ohio Department of Transportation or local jurisdiction
 - 10 feet between a manufactured home and any park roadway, parkway, and the manufactured home park property line

Freestanding Auxiliary Buildings

O.A.C. 4781-12-08.1

- Maximum of 2 freestanding auxiliary buildings per manufactured home lot
- Park established before 1961:
 - 4 feet minimum distance between a freestanding auxiliary building and occupied manufactured home (*so long as the placement does not violate local, state, or federal law)
- Park established in or after 1961:
 - 5 feet minimum distance between a freestanding auxiliary building and occupied manufactured home

Manufactured home parks built before and not substantially altered after December 31, 1960

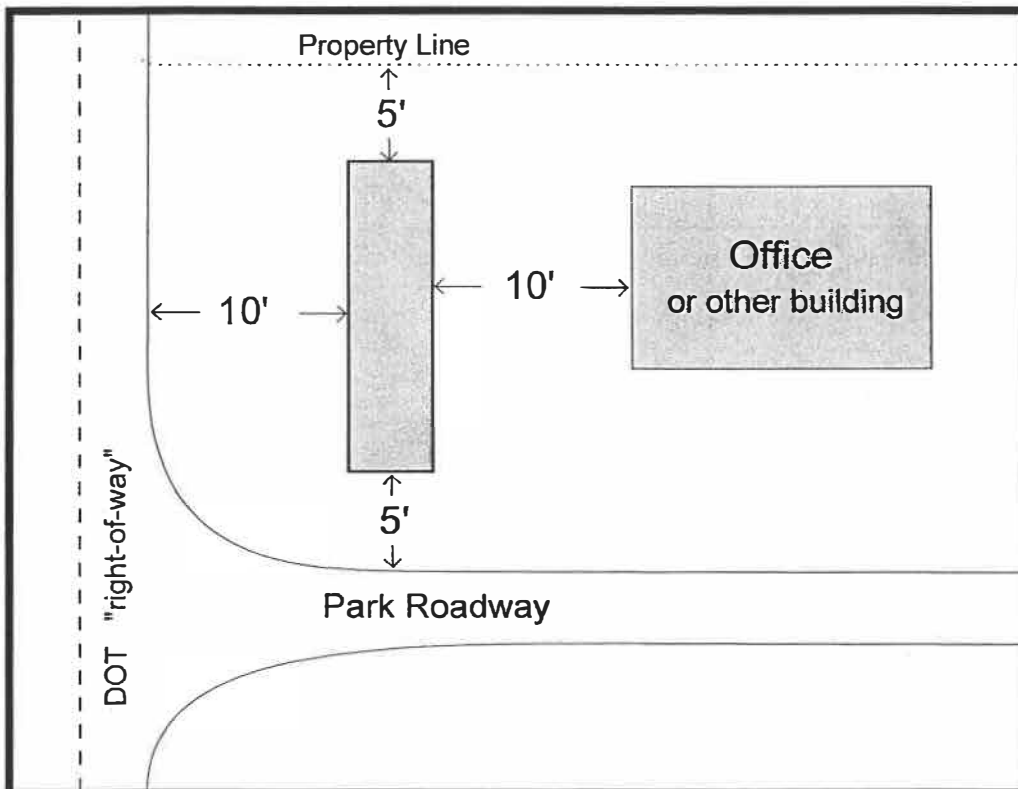
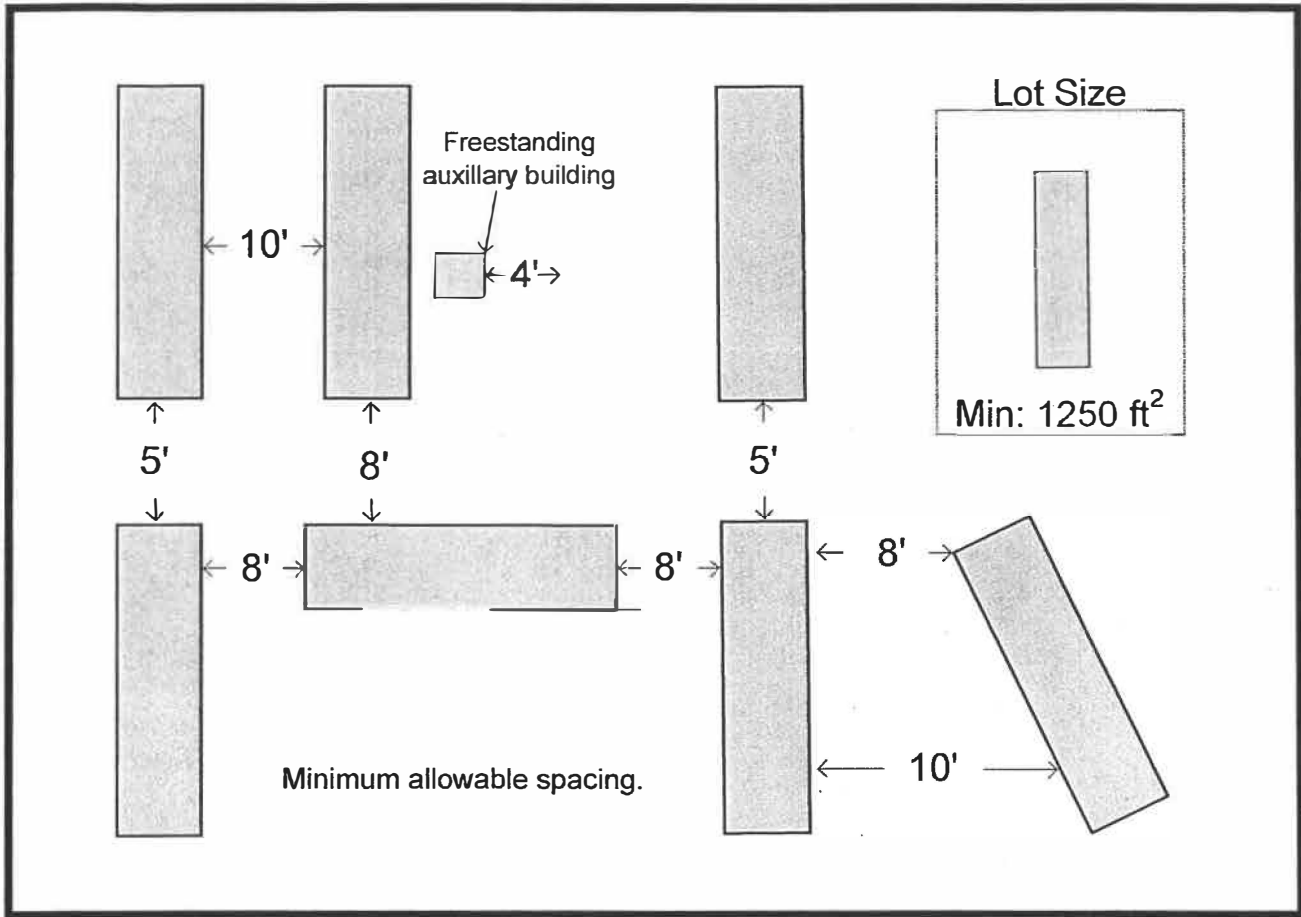

Lot Size - O.A.C. 4781-12-08(A)

Fire Separation Distances - O.A.C. 4781-12-08(E)

Setbacks - O.A.C. 4781-12-08(F)

Auxiliary Buildings - O.A.C. 4781-12-08.1(A)

Manufactured home parks built or substantially altered between Jan. 1, 1961 and June 30, 1971 (and not substantially altered after June 30, 1971)

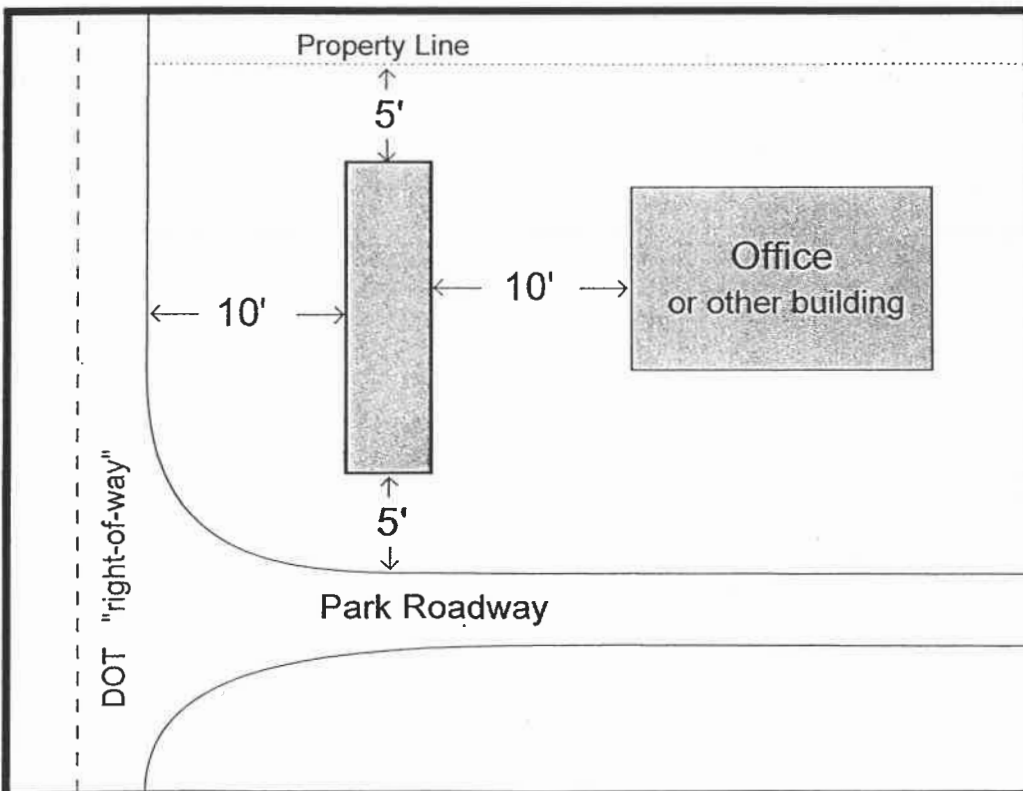
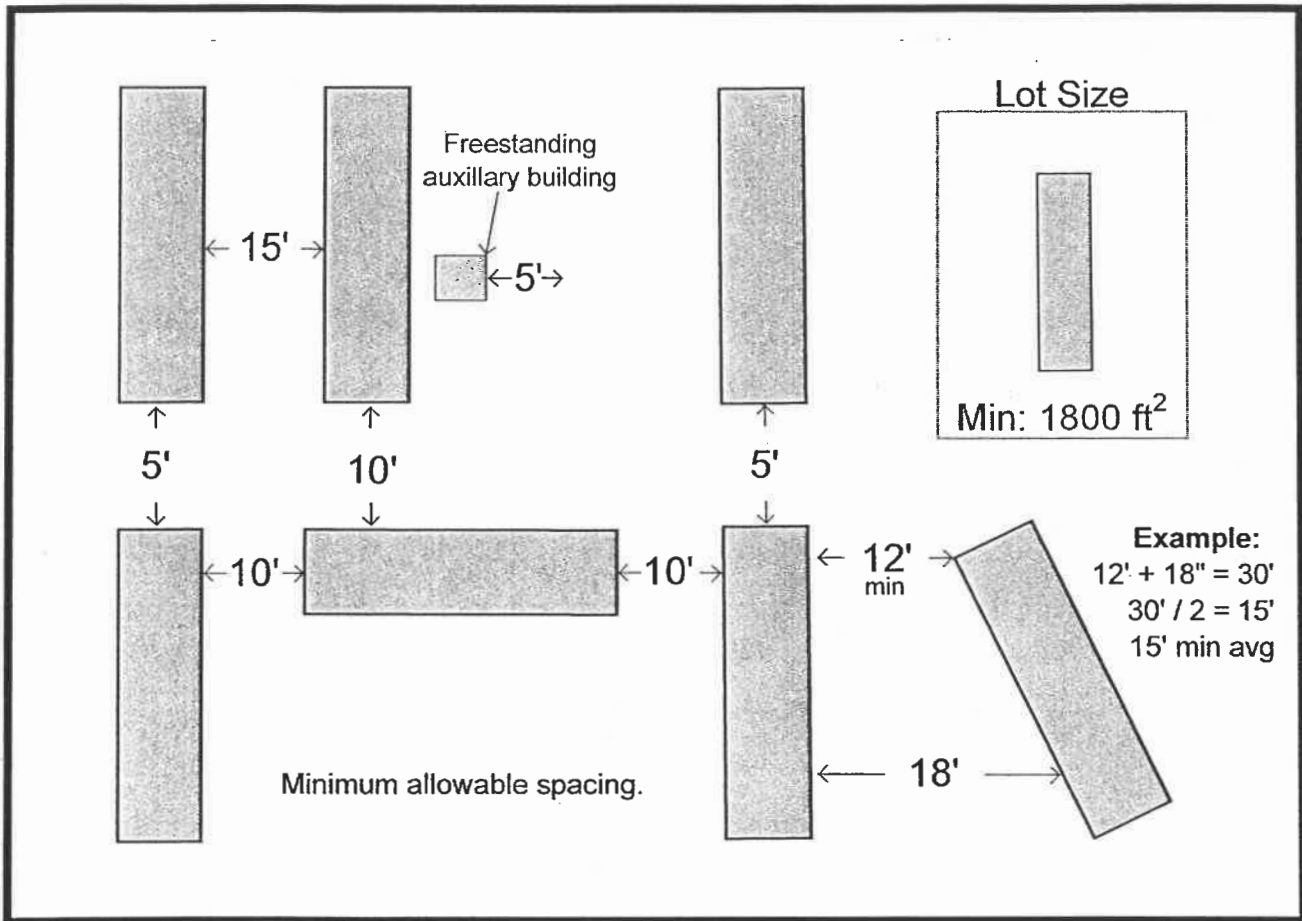

Lot Size - O.A.C. 4781-12-08(B)

Fire Separation Distances - O.A.C. 4781-12-08(G)

Setbacks - O.A.C. 4781-12-08(F)

Auxiliary Buildings - O.A.C. 4781-12-08.1(A)

Manufactured home parks built or substantially altered after June 30, 1971

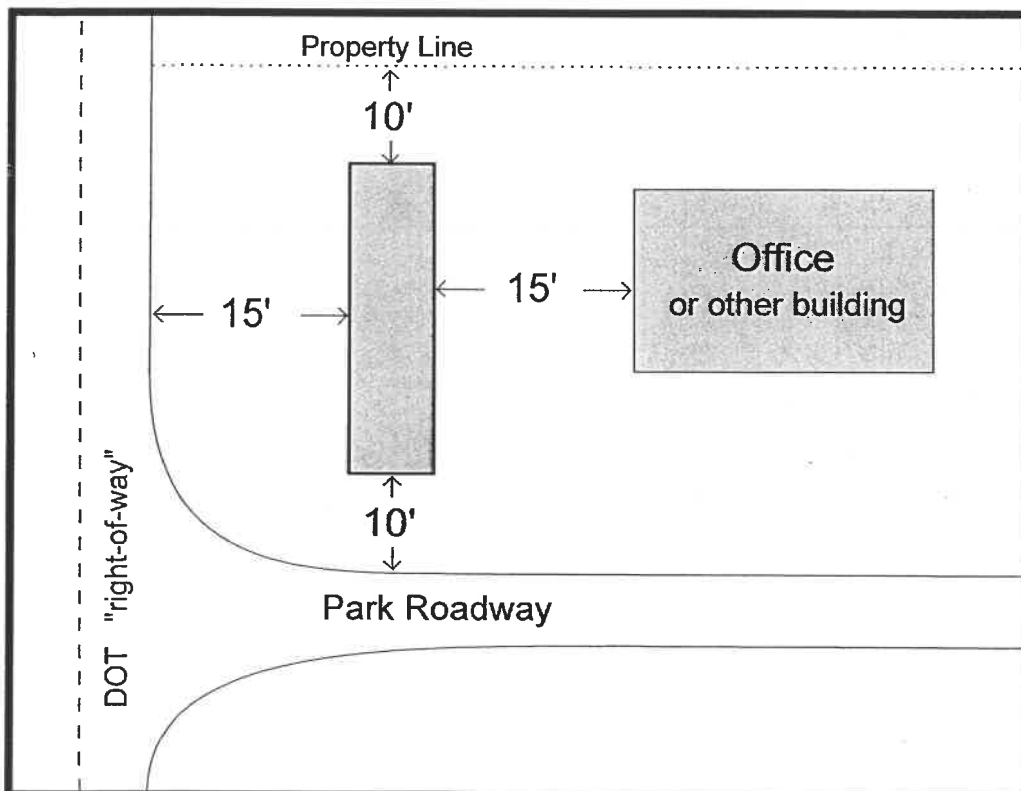
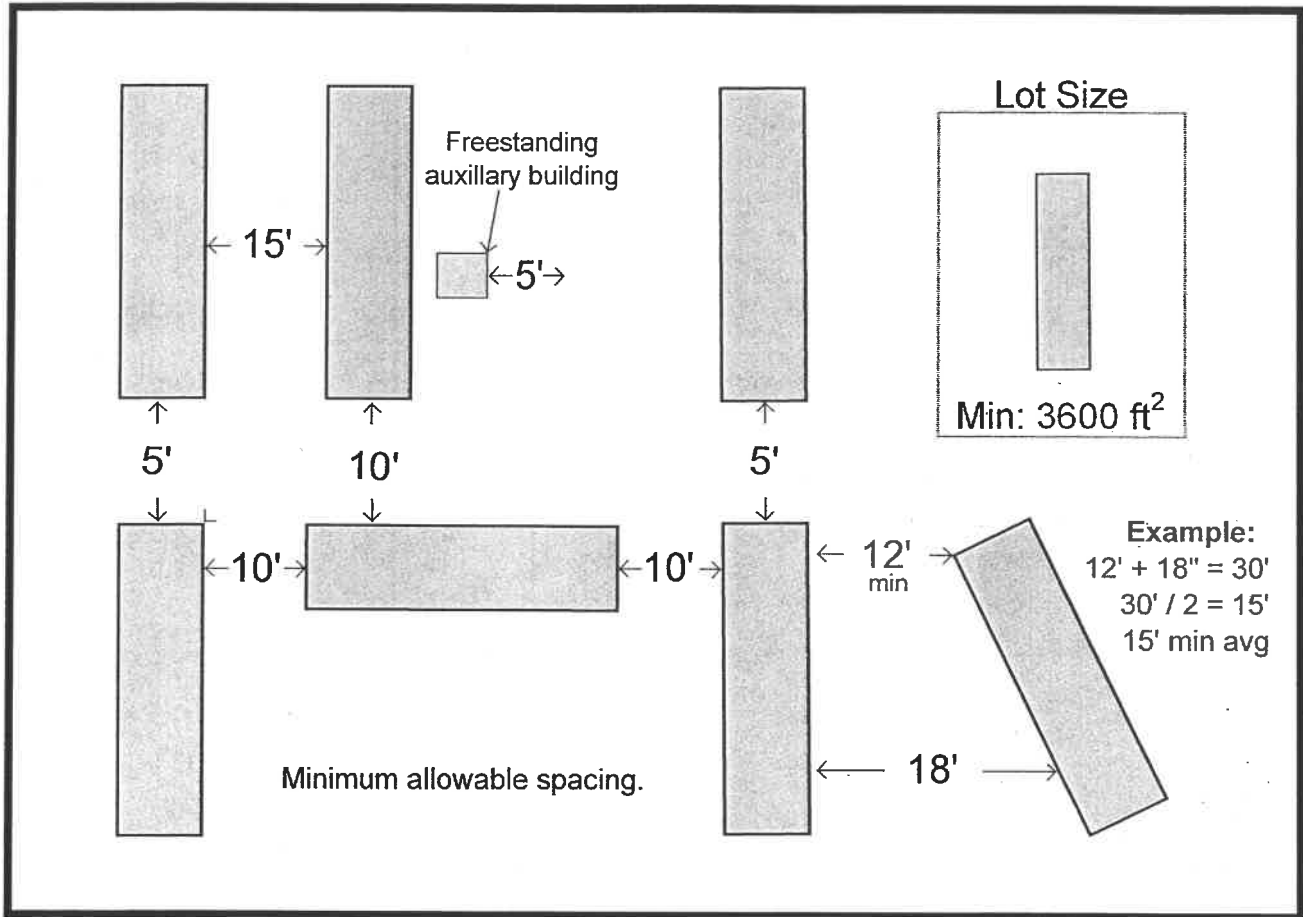

Lot Size - O.A.C. 4781-12-08(C)

Fire Separation Distances - O.A.C. 4781-12-08(G)

Setbacks - O.A.C. 4781-12-08(H)

Auxiliary Buildings - O.A.C. 4781-12-08.1(A)